



Quietflow SINGLE DCV – SQSE & SQSA Installation and Maintenance Instructions

THESE INSTRUCTIONS MUST BE READ FULLY BEFORE COMMENCING INSTALLATION

INDEX

Electrical and Dimensional Data	Page 2
1.0 General	Page 3
2.0 Installation	Page 3
3.0 Start-Up	Page 3
4.0 Fan Maintenance	Page 3
5.0 Principal of Operation	Page 4
6.0 Connections	Page 4
7.0 Control Functions	Page 6
8.0 Operations and Configuration	Page 9
9.0 Parameter List	Page 12
10.0 Wiring	Page 13
11.0 General Functions	Page 14
12.0 Typical Application Setup	Page 15
13.0 EC Declaration of Conformity	Page 16

Electrical and Dimensional Data

PART CODE	SUPPLY	FLC
SQSE100DCV	220V - 240V / 50Hz - 60Hz	0.77
SQSE125DCV	220V - 240V / 50Hz - 60Hz	0.77
SQSE150DCV	220V - 240V / 50Hz - 60Hz	0.75
SQSE200DCV	220V - 240V / 50Hz - 60Hz	0.74
SQSE250DCV	220V - 240V / 50Hz - 60Hz	1.36
SQSE315DCV	220V - 240V / 50Hz - 60Hz	1.4
SQSE400DCV	220V - 240V / 50Hz - 60Hz	3.34
SQSE500/1DCV	220V - 240V / 50Hz - 60Hz	2.97
SQSE500/3DCV	380V - 415V / 50Hz	1.89

PART CODE	SUPPLY	FLC
SQSA100DCV	220V - 240V / 50Hz	0.39
SQSA125DCV	220V - 240V / 50Hz	0.39
SQSA150DCV	220V - 240V / 50Hz	0.39
SQSA200DCV	220V - 240V / 50Hz	0.74
SQSA250DCV	220V - 240V / 50Hz	0.83
SQSA315DCV	220V - 240V / 50Hz	1.3
SQSA400DCV	220V - 240V / 50Hz	1.51
SQSA500DCV	220V - 240V / 50Hz	3.42

Code	A	B	C	D	F	G	Weight kg
SQS100-DCV	514	354	262	100	485	375	19
SQS125-DCV	514	354	262	125	485	375	19
SQS150-DCV	514	354	262	150	485	375	19
SQS200-DCV	589	401	302	200	550	421	21
SQS250-DCV	589	401	332	250	550	421	23
SQS315-DCV	640	490	401	315	580	510	30
SQS400-DCV	705	575	473	400	580	620	41
SQS500-DCV	885	755	602	500	700	800	68

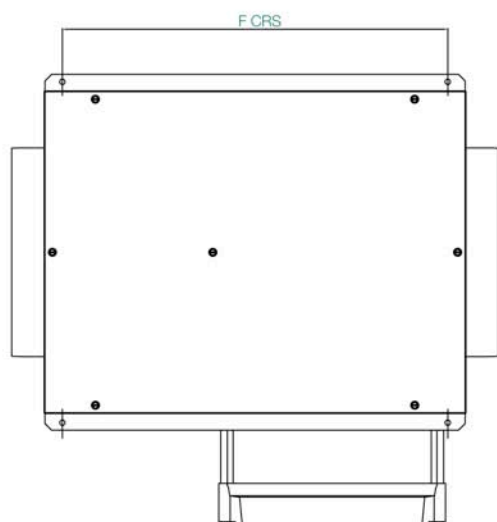
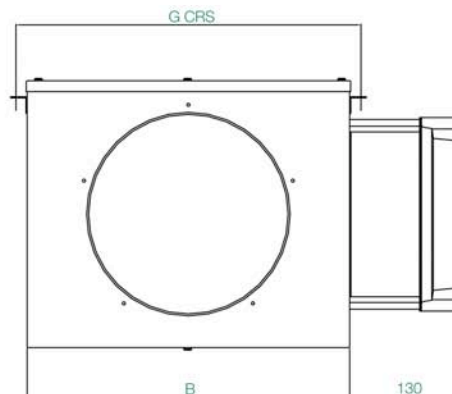
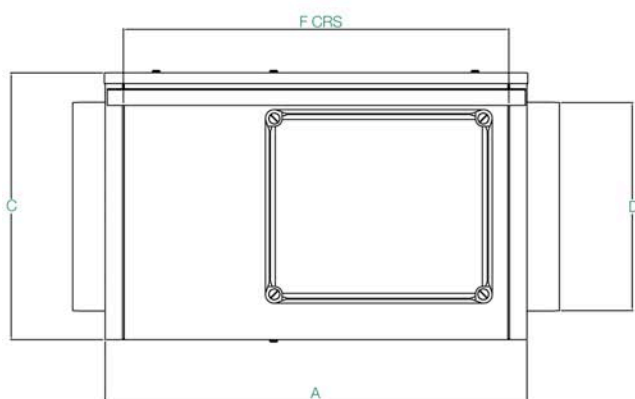

1.0 General

- 1.1 It is important these Installation and Maintenance Instructions are fully adhered to.
- 1.2 Full details of the unit supplied are shown on the product nameplate. If in doubt about any detail contact Elta Fans Ltd or its agents for clarification.
- 1.3 All electrical installation must be carried out by suitably qualified and competent personnel in accordance with all current statutory requirements.
- 1.4 These instructions cover only the Elta Fans Ltd product and do not include the supply or installation of any safety equipment that may be required e.g. adequate guarding or protection from rotating parts and proper electrical isolation.
- 1.5 Any declarations made by Elta Fans Ltd about product installation and safety, are dependant on the fan equipment being used within installations which themselves meet the requirements of the relevant Standards and Directives of your region.
- 1.6 The fan is designed for use in an ambient temperature of -20°C up to +50°C and up to 95% relative humidity. The fan is not suitable for corrosive or explosive atmospheres.
- 1.7 The installer should provide easy access to the fan to facilitate future maintenance.
- 1.8 The installer should ensure the fan is adequately supported.
- 1.9 This product is not intended for use by persons (including children) with reduced physical, sensory or mental capabilities, or lack of experience and knowledge, unless they have been given supervision or instruction concerning use of the product by a person responsible for their safety. Children should be supervised to ensure that they do not play with the product.

2.0 Installation

WARNING – The fan must be isolated from the power supply during installation and maintenance. The fan must be earthed in accordance with the local regulations.

- 2.1 Upon receipt, the fan equipment should be visually inspected to check for any damage. Ensure that the impeller is free to rotate.
- 2.2 If there are any queries concerning the fan equipment, Elta Fans Ltd should be contacted prior to the installation.
- 2.3 The fan must be securely mounted in the desired position to suit the application. The fan can be mounted at any angle.
- 2.4 Check the details on the Fan rating plate to ensure that the correct power supply (voltage, frequency and phase) is available.
An incorrect power supply will lead to permanent damage to the controller and fan motor.
- 2.5 Refer to the appropriate wiring diagram. Ensure that all earth connections are made.
- 2.6 Means for electrical disconnection must be incorporated in the wiring installation in accordance with the relevant wiring and electrical regulations.
- 2.7 Precaution must be taken to locate the exhaust discharge terminal so as to avoid the backflow of gases into the room from the open flue of gas or other fuel burning appliances.

3.0 Start-up

- 3.1 Before power is supplied to the unit, check that the wiring is correct as per the fan connection diagram.
- 3.2 At initial start-up, check that impeller rotation and airflow direction is correct.
- 3.3 Check that the motor amperage draw does not exceed the nameplate rating.

4.0 Fan Maintenance

- 4.1 Inspection of the fan at least once every 12 months is recommended to ensure that the motor, fan blades, and supporting guards, are clean. Any build up of dust and deposits on the blades or guards should be removed using a non-abrasive cleaner.
- 4.2 All fastenings should be checked for tightness. In addition, all rotating items should be checked.
- 4.3 Bearings are of the 'sealed for life' type and will not need a detailed inspection.

WARNING – The EC fan has internal electronic overload protection and the AC fan is fitted with an auto-reset thermal cut-out which switches the fan off in the event of a fault condition.

Once the motor cools down the fan may start unexpectedly.

Only a suitably qualified and competent person may carry out maintenance after the electrical supply has been isolated.

5.0 Principal of Operation

A DCV-ZC1 Zone Controller with DCV-RC1 Room Controller is used to monitor and control one or more fan units which may include a damper, fan and heater. The control input signal (0-10VDC) could be from a temperature, pressure, CO₂ concentration or humidity sensor, from a potentiometer or a BMS system.



6.0 Connections

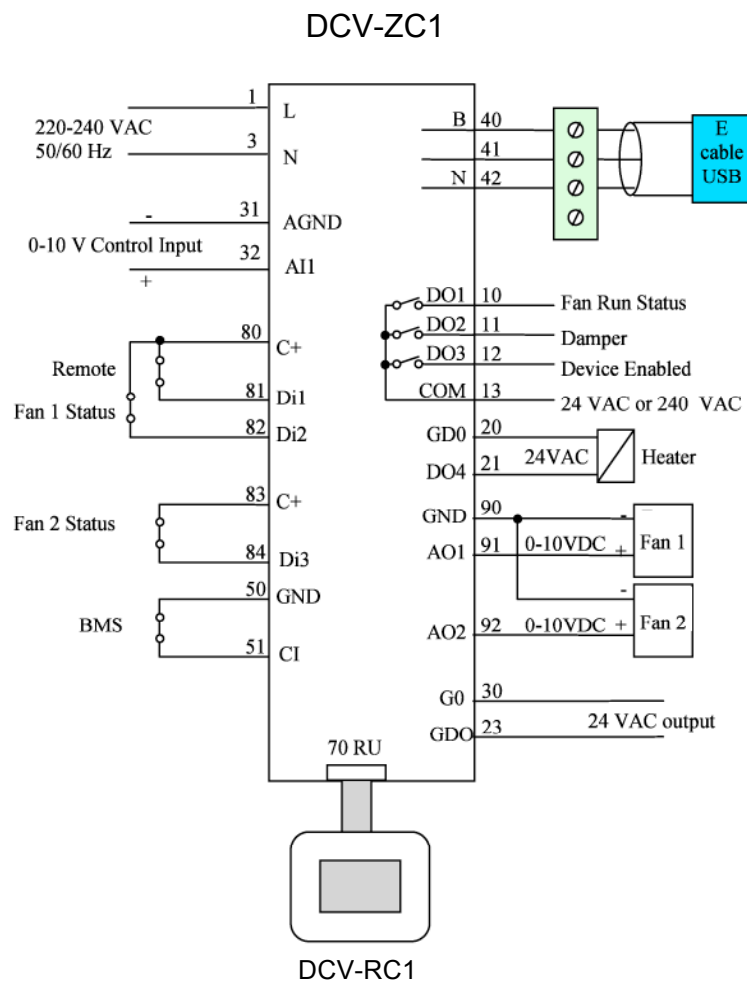

Power

The DCV-ZC1 controller is suitable for 220-240V / 50-60 Hz AC electrical supply.

Digital inputs, 24 VDC out

The C+ terminals (80 & 83) are +24 VDC current limited outputs to be used as common for the digital inputs Di1, Di2 and Di3.

Terminals 80 and 83 are connected to each other internally.

CI digital input (Di8) should be connected to ground (GND) terminal to give BMS Enable = true signal.

Pin	Name	Description
80	+C	+24 V DC output common to Di1 and Di2 +24 V DC output to external device. 0V at G0, pin 30
83	+C	+24 V DC output common to Di3 +24 V DC output to external device. 0V at G0, pin 30
81	DI1	Digital input 1, <i>Remote enable</i> (NC)
82	DI2	Digital input 2, <i>Fan 1 Status</i> (NC)
84	DI3	Digital input 3, <i>Fan 2 Status</i> (NC)
50	GND	Digital input ground
51	CI (DI8)	Digital input 8, <i>BMS Enable</i> (NC)
30	G0	0 V DC/AC.

Digital outputs

DO1-DO3 outputs have relay contacts for 240 VAC or 24 VAC, 6A. DO4 is a 24 VAC MOSFET output for up to 4 A.

Pin	Name	Description
10	DO1	Digital output 1. <i>Fan Run Status</i> . Closed: normal and running
11	DO2	Digital output 2. <i>Damper close/open</i>
12	DO3	Digital output 3. <i>Device enabled</i>
13	COM	Common to DO1-DO3. 240 VAC (Line) or 24 VAC
21	DO4	Digital output 4. <i>Heater Off/On</i>
20	GD0	Digital output ground (DO4)

Analogue inputs

Analogue input signal 0-10 VDC is connected between AI1 and analogue ground (Agnd).

Pin	Name	Description
31	AGnd	Analogue ground
32	AI1	Analogue input 1. <i>Control Input 1</i> , 0-10 VDC. Input signal: temperature, humidity, CO2, pressure, or manual control device

Analogue outputs

The AO terminals carry 0-10 VDC with reference to the **GND** terminal.

Pin	Name	Description
90	Gnd	Reference ground for AO1-AO2.
91	AO1	Analogue output 1, <i>Fan 1 speed</i>
92	AO2	Analogue output 2, <i>Fan 2 speed (slave)</i>

7.0 Control Functions

General

Device Enabled	The fan controller will be enabled if one of the digital inputs <i>Remote Enable</i> or <i>BMS Enable</i> or both are active. This is indicated by digital output <i>Device Enabled</i> = ON.
Damper	The damper is controlled with the digital output <i>Damper</i> and it is ON for the same conditions as <i>Device Enabled</i> .
Control Input signal	When the device is enabled the fan speeds are controlled by the value of the <i>Control Input</i> signal, either by a P-band controller or by a PID controller (pressure control).
Fan Run Status	Fan run status is read at the digital inputs <i>Fan 1 Status</i> and <i>Fan 2 Status</i> . If both fans are OK (no fan failure indicated) this is indicated by digital output <i>Fan Run Status</i> = ON. At fan failure in Twin Fan application the operation will switch over to the other fan.
Heater	An electrical heater can be connected to the digital output <i>Heater</i> , and the output will be ON if: <ul style="list-style-type: none">• The device is enabled, and• the device is running in Temperature control application, and• the input temperature is lower than the set-point. The input signal is compared with the set point using a symmetrical hysteresis of +/- 0.5 °C.

Applications

The controller software is designed to be able to handle 6 different fan applications. Each application has its own set of parameters (input value range, set-points, p band, min and max speeds, etc) and control function. The application is preselected at factory but can be changed in field like the other parameters using the room unit (RU).

In all applications two 0-10 VDC analogue output signals, *Fan 1 Speed* and *Fan 2 Speed*, from the controller are connected to one or two fans.

Applications:

1. **Voltage:** input signal 0-10 VDC determines the fans speed 0-100% of configured max. speed. High input signal gives high fan speed.
2. **Temperature control:** The room temperature (input signal 0-10 VDC ↔ 5-30 °C) is controlled by a P controller (P-band). High temperature gives high fan speed.
3. **CO₂ control.** The room's CO₂ content (input signal 0-10 VDC ↔ 0-2000 ppm) is controlled by a P controller (P-band). High CO₂ rate gives high fan speed.
4. **Humidity control.** The relative humidity in the room (input signal 0-10 VDC ↔ 30-95 %) is controlled by a P controller (P-band). High humidity value gives high fan speed
5. **Pressure control.** Duct air pressure (input signal 0-10 VDC ↔ 0-300 Pa) is controlled by a PID controller (Proportional, Integration and Derivation). High pressure value gives low fan speed. (SQSA range **NOT RECOMMENDED**)
6. **Manual fan speed control.** The fan speed is set manually using the room unit's increase and decrease buttons.

Functions

Fan speed control

The controller's main task is to set the speed of one or two fans in order to maintain a measured input signal at the configured set point value. The fan's status is also monitored. A damper and a heater can be connected to digital outputs and will then be controlled by the controller.

Two fans	When two fans are used they can be running as master/slave fans with the fans mounted in different fan units, or they can be running in twin mode, where both fans are mounted in the same fan unit. In twin mode the run and standby fans operate on a six hour duty share cycle.
P-band, PID	For all applications (voltage, temperature, humidity, etc) except the pressure control and the manual control the fan speeds are controlled with a P-band controller. For pressure control the speed is controlled by a PID controller. For manual control the output signal is set directly from the room unit.
Manual speed settings	During commissioning of the unit the fan speeds can be set manually to any value between 0 and 100% for all application to test the fan operation. Please note that 100% corresponds to the configured max fan speeds.

Master/Slave fans

The two fans are mounted in different fan units for instance the master fan is the inlet supply air fan and the slave fan is the return air fan. The speed of the slave fan will be the same as the master fan's speed, but since the two fans can have different min and max speed settings the actual fan speeds will not be exactly the same. See below: *Min & Max fan speeds*.

A failure on one of the fans will not affect the operation (analogue output) of the other fan.

When both fans are operational the *Fan Run Status* digital output is set high, otherwise it will be reset.

Twin fans

The two fans are mounted in the same fan unit, and only one fan is operational at a time. The other fan acts as a backup fan and will be running if there is a fan failure. There is also a change over schedule: every 6th hour the fans will change duty and the operational fan will be the backup fan and vice versa.

When both fans are operational the *Fan Run Status* digital output is set high, otherwise it will be reset. Please note that a fan failure must be acknowledged before the fan can be running again.

Min & Max fan speeds

The controller calculates the required fan speed 0 - 100 % (*FanSpeed*). But the actual fan speed is dependant of the configuration of the parameters: *MinFanSpeed*, *MaxFanSpeed* and *FanTrickleSpeed*. 100% fan speed means that the fan will run at the configured maximum speed.

- If both *Remote Enable* and *BMS Enable* inputs are closed the fan speed is determined by the analogue input signal. The fan speed will never be lower than *MinFanSpeed* and will never be higher than *MaxFanSpeed*.
- If *BMS Enable* is closed and *Remote Enable* is open the fan speed will be set to *FanTrickleSpeed*
- If both *Remote Enable* and *BMS Enable* are open the fan will be stopped.

The two fans (Master/Slave or Twin fans) have individual min and max speed parameters.

Fan failure

Each fan has a running indication signal connected to digital inputs. The inputs are high when the fans are running.

Fan failure is determined if the *BMS Enable* is closed and the fan running input has not increased to high after 10 seconds.

Control applications

Voltage 0-10V input

A 0-10 VDC input signal (BMS or from a potentiometer) is used to set the fan speed output signals.

Display symbol: none Display unit: none

Input voltage range (VDC)	Setpoint (VDC)	P-band (VDC)	Input values (VDC) when Fan speed =:		Output value increases when input value:
			20%	100%	
0-10	5	10	2	10	increases

Temperature control

A temperature sensor with 0-10 VDC output signal is used to set the fan speed output signals in order to maintain the measured temperature at the set-point value.

Display symbol:  Display unit: °C

Input temperature range (°C)	Setpoint (°C)	P-band (°C)	Input values (°C) when Fan speed =:		Output value increases when input value:
			20%	100%	
5-30	22	5	19.5	24.5	increases

CO₂ control

A CO₂ sensor with 0-10 VDC output signal is used to set the fan speed output signals in order to maintain the measured CO₂ concentration at the set-point value.

Display symbol: **CO₂** Display unit: **ppm**

Input CO ₂ conc. Range (ppm)	Setpoint (ppm)	P-band (ppm)	Input values (ppm) when Fan speed =:		Output value increases when input value:
			20%	100%	
0-2000	1000	1000	500	1500	increases

Relative Humidity control

A relative humidity (RH) sensor with 0-10 VDC output signal is used to set the fan speed output signals in order to maintain the measured RH at the set-point value.

Display symbol: **RH** Display unit: %

Input RH range (% RH)	Setpoint (% RH)	P-band (% RH)	Input values (% RH) when Fan speed =:		Output value increases when input value:
			0%	100%	
30-95	70	40	50	90	increases

Pressure control

A pressure sensor with 0-10 VDC output signal is used to set the fan speed output signals in order to maintain the measured pressure at the set-point value.

Display symbol:  Display unit: none

Input pressure range (Pa)	Setpoint (Pa)	P,I,D (Pa,s,s)	Input values (Pa) when output signal =:		Output value increases when input value:
			0%	100%	
Adjustable from 0-50 to 0-1000 Default: 0-300	150	-200,10,0	NA	NA	decreases

Manual control

The fan speeds are set manually between 0 and 100% using the room unit's increase and decrease buttons.

Display symbol: 

Display unit: %



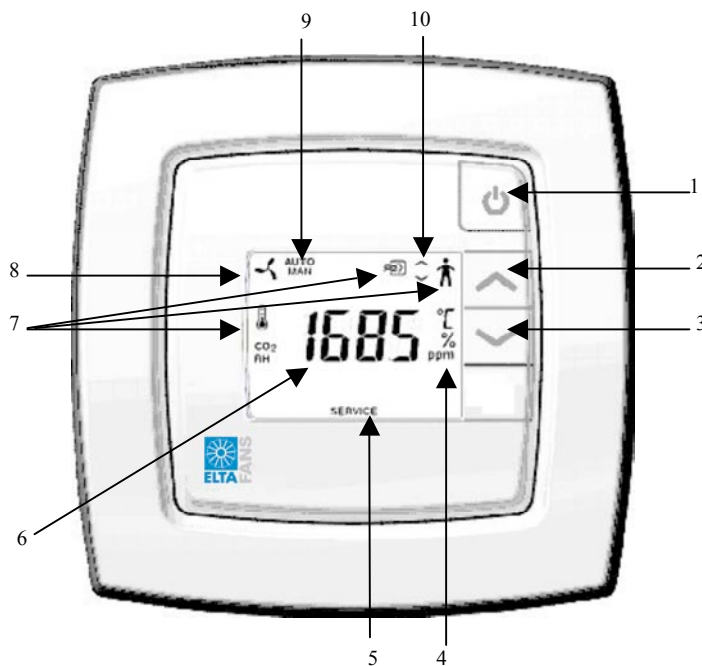

8.0 Operation and Configuration

Room Unit with display



Buttons/Display

1. **Acknowledge.** Is used to:
 - a. enter a parameter to edit in Parameter Edit mode
 - b. to acknowledge a parameter change and return to the parameter list in the Parameter Edit mode
 - c. to acknowledge and reset a fan failure
2. **Increase.** Is used to:
 - a. select from the parameter list in Parameter List mode
 - b. to increase a parameter value in Parameter Edit mode.
 - c. If both increase and decrease buttons are pressed at the same time for at least 5 seconds the Parameter List mode is entered
 - d. To increase the fan speed in manual control
3. **Decrease.** Is used to:
 - a. select from the parameter list in Parameter List mode
 - b. to decrease a parameter value in Parameter Edit mode.
 - c. If both increase and decrease buttons are pressed at the same time for at least 5 seconds the Parameter List mode is entered
 - d. To decrease the fan speed in manual control

4. **Units.** For each application different unit symbols will be shown. Voltage and pressure applications do not have any units.
5. **Service.** Is visible during the process to enter Parameter List mode.
6. **Value.** Input signal value or parameter value. In the parameter list the text P01, P02 etc is shown instead of a value. At fan failure (one or both fans) the text **FAIL** will flash together with the value.
7. **Applications.** Indicate selected application:
 - a.  for Temperature control
 - b. **CO₂** for CO2 control
 - c. **RH** for Humidity control
 - d.  for pressure control
 - e.  for Manual control
8. **Fan running.** A fan blade symbol () is used to indicate the status of the fans:
 - a. A rotating fan blade symbol indicates that at least one fan is running: *BMS Enable* is closed
 - b. A stationary fan blade symbol indicates that the fans are stopped but OK: *BMS Enable* is open
 - c. No visible fan blade symbol indicates that the fans are not running due to fan failure (both fans). To resume operation the fan failure must be acknowledged by pressing the *Acknowledge* button (1).
9. **AUTO/MAN.** Indicates whether the fans are in Auto or Manual mode. Auto mode is when the parameter P09 is set to 1, even for the manual application. Manual mode is only used when the unit is commissioned. The normal operation is AUTO; the room controller is only used to display the measured value and the fan run status.
10. **Increase/Decrease.** Flashing symbols indicate that the increase or decrease button can be used to select a parameter in the parameter list or to modify a parameter in parameter edit mode.

Operation

In normal operation the room unit is only used as a display to view the analogue input value (in engineering units) and the fan running status.

In Manual application the fan speed is set using the Increase and Decrease buttons. Press one of the buttons repeatedly or hold continuously to increase or decrease the fan speeds.

Configuration

The fan controller has a list of parameters. By setting the parameter values you can select fan application, min and max fan speeds, set-points etc.

To enter the Parameter List mode:

- Press the **Increase** and **Decrease** buttons at the same time for at least 5 seconds or until the **SERVICE** symbol at the display bottom will be turned on and the **Increase** symbol in the top right corner will start to flash.
- Press **Increase** button twice. The text “P01” (for Parameter 1) will appear on the display. Select parameter number with **Increase** or **Decrease** buttons.

To enter Parameter Edit mode

- Press **Acknowledge** button to view the value of the selected parameter.
- The parameter value can be increased or decreased with the buttons. Confirm and return to Parameter List mode with **Acknowledge** button.
- Leave the Parameter List mode by pressing **Increase** and **Decrease** buttons at the same time shortly.

Parameter settings

Parameter descriptions

Each application has its own set of default parameter settings and also the corresponding min and max values, so when you select an application several parameters will have new default values. If you modify parameters for one application and then change to another application the modified values will be stored with the old application before the application's parameters are valid.

Parameters P01 to P05 are individuals for each application, while the rest of the parameters are common for all applications.

P01: Fan application	Select application for different types of analogue input signals. <ol style="list-style-type: none">1. Voltage control2. Temperature control3. CO2 control4. Humidity control5. Pressure control (SQSA range NOT RECOMMENDED)6. Manual control
P02: Set-point	The set-point is used for applications 1-5. For applications 1-4 the fan speed is 0% for input signal = Set-point - $\frac{1}{2}$ P-band and is 100% for input signal = Set-point + $\frac{1}{2}$ P-band. For application 5 (Pressure) a PID controller is used and the fan speed output signal will be integrated up or down as long as the input signal differs from the set-point value.
P03: Prop band	Proportional band is the range of the input signal required to give an output signal from 0 to 100 %.
P04: Integration time	PID controller's Integration time in seconds. Is used only in application Pressure.
P05: Derivation time	PID controller's Derivation time in seconds. Is used only in application Pressure.
P06: Min Fan Speed	The minimum speed at which the Master fan will be running.
P07: Max Fan Speed	The maximum speed at which the Master fan will be running.
P08: Trickle Speed	The minimum calculated Master fan speed required to give an output signal > 0.
P09: Fan Manual/Auto	During commissioning the fan speed can be set manually to check inverters and fans. Set the parameter = 0 for manual mode and then go to next parameter, P10, to set the manual speed. Please note that this manual mode is not the same as the manual application, where the fan speed will be set manually in normal operation.
P10: Fan Manual Speed	See P09.
P11: Run On Time Secs	Run-On Time is the time the fan will be running after removal of the digital inputs <i>Remote</i> and <i>BMS</i> . This parameter determines the Run-On Time in seconds, and P12 determines the time in minutes. The total Run On Time is P12 minutes and P11 seconds.
P12: Run On Time Mins	See P11.
P13: Twin fans	Setting "0" means Master/Slave fans. Setting "1" means Twin fans
P14: Slave Min Speed	The minimum speed at which the Slave fan will be running.
P15: Slave Max Speed	The maximum speed at which the Slave fan will be running.
P16: Slave Trickle Speed	The minimum calculated Slave fan speed required to give an output signal > 0
P17: Pressure Range	The range of the pressure sensor which is connected to the system

9.0 Parameter List

Parameter	Default Value	Min Value	Max Value	Unit
P01: Fan Application	1	1	6	1: Voltage 2: Temperature 3: CO ₂ 4: RH 5: Pressure 6: Manual speed
P02: Set-point				
Voltage	5	0	10	V
Temperature	22	15	30	°C
CO ₂	1000	0	2000	ppm
RH	70	30	95	%
Pressure	150	0	1000	Pa
P03: Prop. Band				
Voltage	10	1	10	V
Temperature	5	5	30	°C
CO ₂	1000	500	2000	ppm
RH	40	20	95	%
Pressure	200	50	300	Pa
P04: Integration Time				Seconds
Voltage	0	0	0	
Temperature	0	0	0	
CO ₂	0	0	0	
RH	0	0	0	
Pressure	10	0	500	
P05: Derivation Time				Seconds
Voltage	0	0	0	
Temperature	0	0	0	
CO ₂	0	0	0	
RH	0	0	0	
Pressure	0	0	500	
P06: Min Fan Speed	20	0	50	%
P07: Max Fan Speed	100	50	100	%
P08: Trickle Speed	20	0	50	%
P09: Fan Manual/Auto	1	0	1	Manual, Auto
P10: Fan Manual Speed	0	0	100	%
P11: Run On Time Secs	0	0	59	Seconds
P12: Run On Time Mins	0	0	59	Minutes
P13: Twin Fans	0	0	1	No, Yes
P14: Slave Min Speed	20	0	50	%
P15: Slave Max Speed	100	50	100	%
P16: Slave Trickle Speed	20	0	50	%
P17: Pressure Sensor Range	300	50	1000	Pa

10.0 Wiring

Diagram A: Connections Schematic

DCV Bottom tier connections

DCV 1Ph Supply Unit

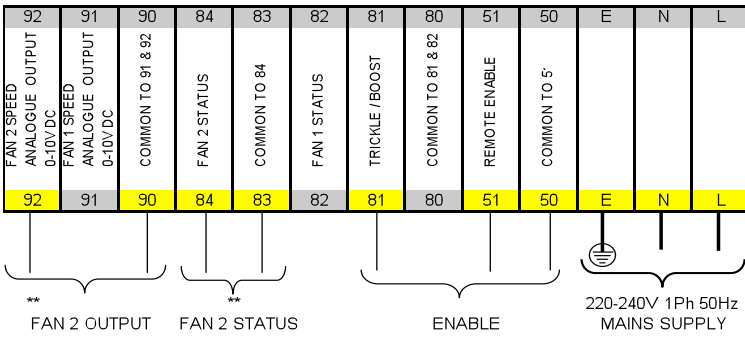

** FAN 2 : RECOMMENDED SLAVE UNIT

DCV Top tier connections

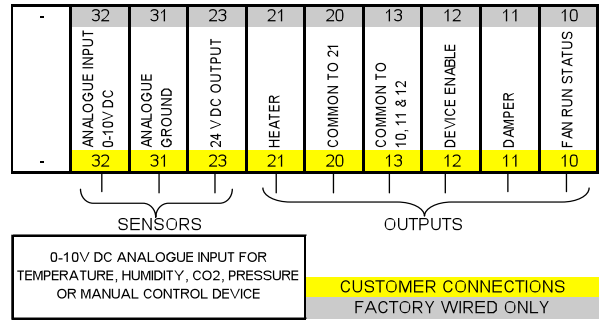

DCV Bottom tier connections

DCV 3Ph Supply Unit

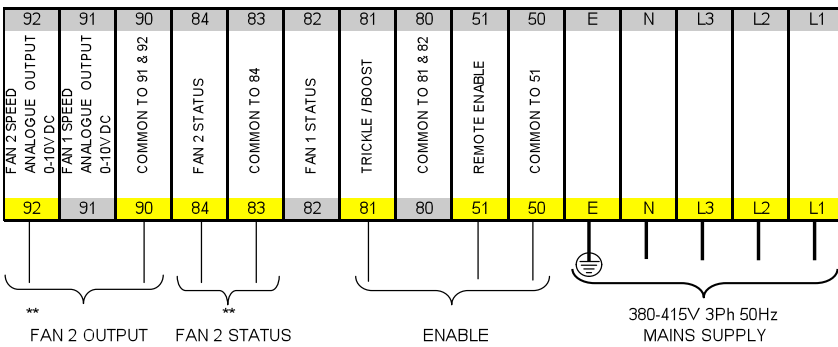

** FAN 2 : RECOMMENDED SLAVE UNIT

Diagram B: Sensor Connection (0-10V)

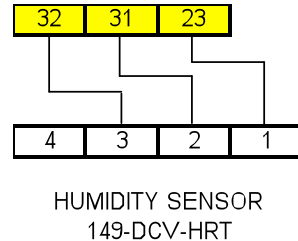
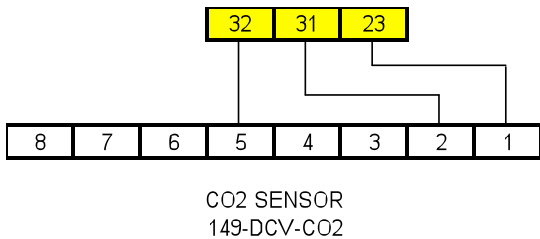
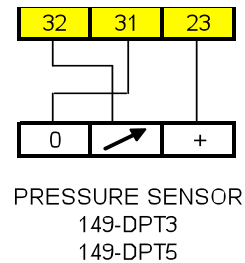
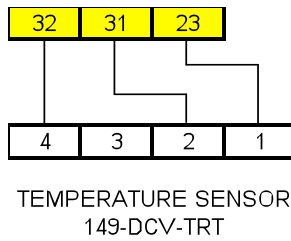
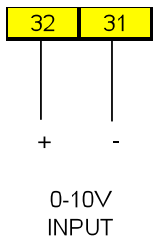
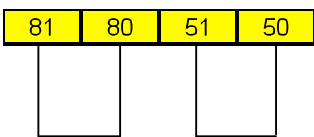
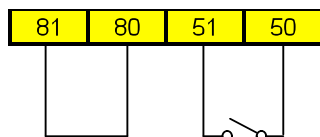

Diagram C: Enable Configuration



NO ON / OFF
NO TRICKLE / BOOST



ON / OFF
NO TRICKLE / BOOST

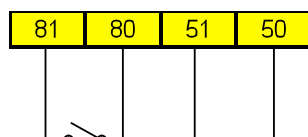

ON / OFF
TRICKLE / BOOST

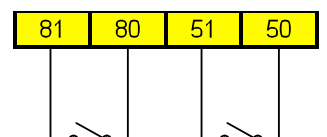

ON / OFF
TRICKLE / BOOST

11.0 General Functions

Device Enabled

With either or both trickle/boost (80&81) and on/off (50&51) input connections closed, the device enabled output (12&13) will be closed

Fan Speed

With both trickle/boost (80&81) and on/off (50&51) input connections closed, the fan speed is controlled by the sensor signal.

Trickle/Boost

With both trickle/boost (80&81) and on/off (50&51) input connections closed, the fan speed is controlled by the sensor signal.

With trickle/boost (80&81) input connection open and on/off (50&51) input connection closed, the fan speed is controlled by the min speed setting. An adjustable run on time is also available via Parameter list.

Fan Run Status

Fan run status is read at the digital inputs *Fan 1 Status* and *Fan 2 Status*. If both fans are OK (no fan failure indicated) this is indicated by digital output *Fan Run Status* = ON. At fan failure in Twin Fan application the operation will switch over to the other fan.

With Fan 1 status (80&82), Fan 2 status (83&84) and on/off (50&51) input connections closed, the fan run status output (10&13) will be closed. If any of these input connections are open then the fan run status output will be open.

If either Fan 1 status (80&82) or Fan 2 status (83&84) input connections are open, the room controller will display "FAIL". In the event that both Fan 1 status (80&82) and Fan 2 status (83&84) input connections are open, the room controller will display "FAIL" and the  symbol will disappear. If the reset button is pressed the fan output will be enabled for 10 seconds to verify that the fail has been cleared; if it has not the room controller will again show "FAIL".

Damper

The damper output (11&13) is closed unless both trickle/boost (80&81) and on/off (50&51) input connections are open. This connection can be used to control the control circuit of a damper.

Heater

The heater connections (20&21) provide a 24VAC output to control the circuit of a heater; 24VAC will be present as long as the device is enabled, the application is in temperature control and the sensor input temperature is less than the set point.

11.0 Typical Application Set Up

The room controller has a list of parameter options. By setting the parameter values you can select the fan application, minimum and maximum fan speeds, set points, etc.

To enter the Parameter List mode:

- Press the *Increase* and *Decrease* buttons at the same time for at least 5 seconds or until the *SERVICE* symbol at the bottom of the unit is displayed and the **Increase** symbol in the top right corner starts to flash.
- Press the *Increase* button twice. The text "P01" (for Parameter 1) will appear on the display. Select the parameter number with the *Increase* or *Decrease* buttons.

To enter the Parameter Edit mode:

- Press the *Acknowledge* button to view the value of the selected parameter.
- The parameter value can be increased or decreased using the *Increase* or *Decrease* buttons. Confirm and return to the Parameter List mode with the *Acknowledge* button.

Leave the Parameter List mode by briefly pressing the *Increase* and *Decrease* buttons at the same time.

Example: Temperature

- 1) Connect unit as Diagram "A" on page 13
- 2) Connect Sensor 149-DCV-TRT as Diagram "B" on page 13
- 3) Connect Enable configuration as Diagram "C" on page 13
- 4) When enabled the Room Controller will display default mode
- 5) Enter parameter list mode and change PO1 to "2"
- 6) Exit Parameter List if Default settings meet requirement
- 7) The fan will now operate automatically in Temperature mode

GUARANTEE

Elta Fans Ltd will, free of charge, within a period of 1 year from the date of despatch from their works, repair or at its option replace any goods which are proved to have defects as a result of defective materials or workmanship. The goods MUST be returned to Elta Fans Ltd carriage paid for examination.

Elta Fans Ltd

17 Barnes Wallis Road
Segensworth East Industrial Estate
Fareham, Hampshire, PO15 5ST, United Kingdom

Visit: eltafans.com

e-mail: mailbox@eltafans.co.uk

Applied Technology: **Tel:** +44(0) 1489 566500 **Fax:** +44(0) 1489 566555

Building Services: **Tel:** +44(0) 1384 275800 **Fax:** +44(0) 1384 275810

Export: **Tel:** +44(0) 1489 566500 **Fax:** +44(0) 1489 566555

EC DECLARATION OF CONFORMITY

As defined by the EC Council Directive on Machinery 98/37/EC

Herewith we declare that the air movement equipment below, on the basis of its design and construction in the form brought onto the market is in accordance within the relevant health and safety requirements of the EC Directive for use of machinery.

If alterations are made to the machinery without prior consultations with us, this declaration becomes invalid.

Designation of equipment:

Quietflow DCV Range - SQS Single

Series / Type:

Single Phase - 220V - 240V / Three Phase - 380V - 415V

SQSA100

SQSE100

SQSA125

SQSE125

SQSA150

SQSE150

SQSA200

SQSE200

SQSA250

SQSE250

SQSA315

SQSE315

SQSA400

SQSE400

SQSA500/1

SQSE500/3

Serial Number:

Relevant EC Council Directives:

Machinery Directive **(98/37/EC)** and amendments
 Low Voltage Directive **(73/23/EEC)** and amendments
 Directive on Electromagnetic Compatibility **(89/336/EEC)** and amendments

Date / Signature of Manufacturer:

26/02/2009



Name and Position of Signatory:

B.REES

Q. A. Manager

